

MOP WHEELS

ABRASIVE CLOTH

OPERATIONAL REMARKS

Abrasive tools used mostly for smoothing and finishing materials of complex shapes, preparing surfaces for further treatment.

The features of flap wheels include : relatively low utilization of a tool, preserving a profile of tool, high efficiency of grinding and quality of grinded surface.

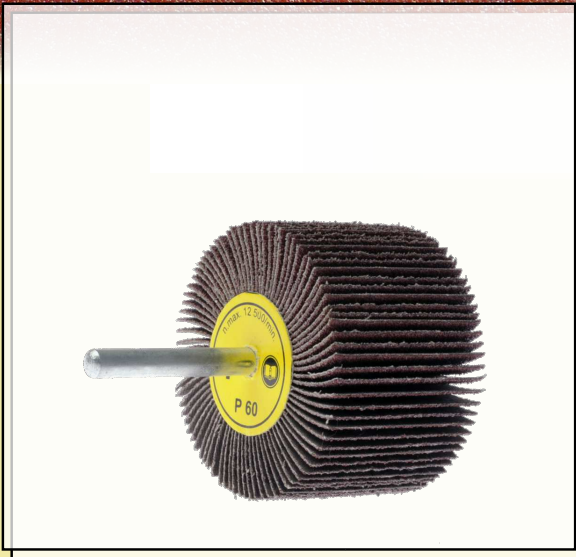
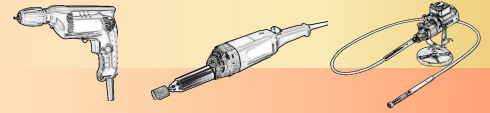

CORUNDUM

DIMENSIONS D x H [mm]	d [mm]	n opt. [1/min]	n max [1/min]	GRIDS											
ø10 x 10	ø3 lub ø6	38.000 - 57.000	75.000	-	-	80	100	120	150	180	220*	240	280*	320	
ø15 x 10	ø3 lub ø6	25.000 - 38.000	50.000	-	-	80	100	120	150	180	220*	240	280*	320	
ø20 x 10, x 15 x 20	ø3 lub ø6	19.000 - 28.000	36.000	-	60	80	100	120	150	180	220*	240	280*	320	
	ø3 lub ø6	19.000 - 28.000	36.000	40	60	80	100	120	150	180	220*	240	280*	320	
ø25 x 10, x 15, x 20 x 25	ø3 lub ø6	15.000 - 22.000	30.000	40	60	80	100	120	150	180	220*	240	280*	320	
	ø3 lub ø6	15.000 - 22.000	30.000	40	60	80	100	120	150	180	220*	240	280*	320	
ø30 x 5, x 10 x 15, x 20, x 25 x 30, x 40	ø3 lub ø6	12.000 - 19.000	25.000	40	60	80	100	120	150	180	220*	240	280*	320	
	ø6	12.000 - 19.000	25.000	40	60	80	100	120	150	180	220*	240	280*	320	
	ø6	12.000 - 19.000	25.000	40	60	80	100	120	150	180	220*	240	280*	320	
ø40 x 10, x 15, x 20 x 30, x 40	ø6	9.500 - 14.000	20.000	40	60	80	100	120	150	180	220*	240	280*	320	
	ø6	9.500 - 14.000	20.000	40	60	80	100	120	150	180	220*	240	280*	320	
ø50 x 10, x 15, x 20 x 30, x 40	ø6	7.500 - 11.000	15.000	40	60	80	100	120	150	180	220*	240	280*	320	
	ø6	7.500 - 11.000	15.000	40	60	80	100	120	150	180	220*	240	280*	320	
ø60 x 10, x 15, x 20 x 30, x 40, x 50	ø6	6.300 - 9.500	12.500	40	60	80	100	120	150	180	220*	240	280*	320	
	ø6	6.300 - 9.500	12.500	40	60	80	100	120	150	180	220*	240	280*	320	
ø70 x 20, x 30, x 40	ø6	5.400 - 8.100	10.500	40	60	80	100	120	150	180	220*	240	280*	320	
ø80 x 10, x 15, x 20 x 30, x 40, x 50	ø6	4.700 - 7.100	9.500	40	60	80	100	120	150	180	220*	240	280*	320	
	ø6	4.700 - 7.100	9.500	40	60	80	100	120	150	180	220*	240	280*	320	
ø100 x 10, x 30, x 40 x 50	ø6	3.800 - 5.700	7.500	40	60	80	100	120	150	180	220*	240	280*	320	
	ø6	3.800 - 5.700	7.500	40	60	80	100	120	150	180	220*	240	280*	320	

* - available on individual order

APPLIANCE:

- grinding of flat, convex and concave surfaces, profiled elements
- various materials, such as steel, stainless steel, aluminium, plastic, wood

Peripheral speed ensuring optimum efficiency of work : 20 - 30 m/s

Proper speed and pressure allows for temperature reduction and minimizes utilization of tool during grinding process. With addition of cooling and lubricant substances (oil), the efficiency of grinding process increases.

On individual order we also offer tools made of Zirconium and Silicon Carbide, as well as grids 400 and 600.

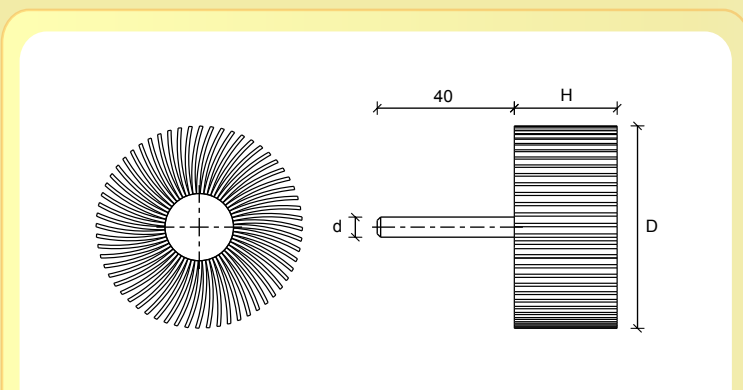

Spindle mop wheels